

# FLEXIBLE INSULATING SYSTEMS



ENERSAVE

THERMOPROOF

NANOTECH

TERMO-JACKET

PROSOUND-JACKET

PYROPROOF®

**NEW** **COMPONIT**  
textile solutions for heat treatment

# WHEREVER THERE ARE HIGH TEMPERATURE TO MANAGE, WE ARE THERE.



Our company is specialised in **custom-made solutions**, for any problems related to **HEAT** and **TEMPERATURE CHANGES**, but also **NOISE**, **COLD** and **FIRE**.

For over **30 years** we have brought our engineering experience from **Cirimido (CO)** all the world, facing any kind of **plant problems and finding innovative solutions**:

- **Bench Test up to 600°C** of temperature: raw materials and products are tested in extreme conditions
- Technical team for **3D or 2D design**
- Our registered efficiency evaluation method **Efficiency Box®** to check, analyse and satisfy any need
- **Eiif accredited for the evaluation of energy saving**

**Any NEW COMPONIT project follows a quality path.**  
We patented proprietary processes for the design,  
**testing and installation** of our products:  
a **further guarantee** that no detail will be forgotten.

**Only New Componit flexible and removable insulations  
are designed, produced and installed with**

**NOHEAT®**

- **Custom-made design with temperature or noise study, dimensional survey on site or 3D engineering**
- **Production with first choice materials and cutting-edge technologies**
- **Installation performed by a team of experts**

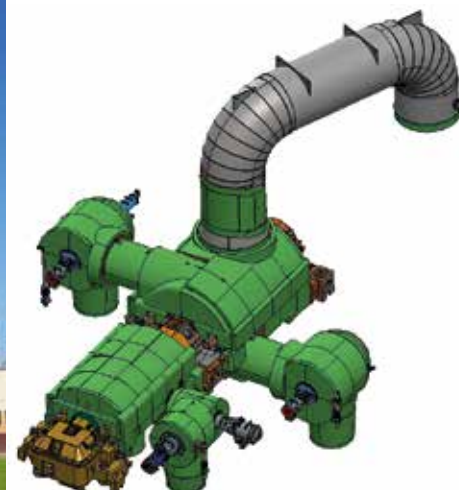



# SERVICES

## Thermographic studies

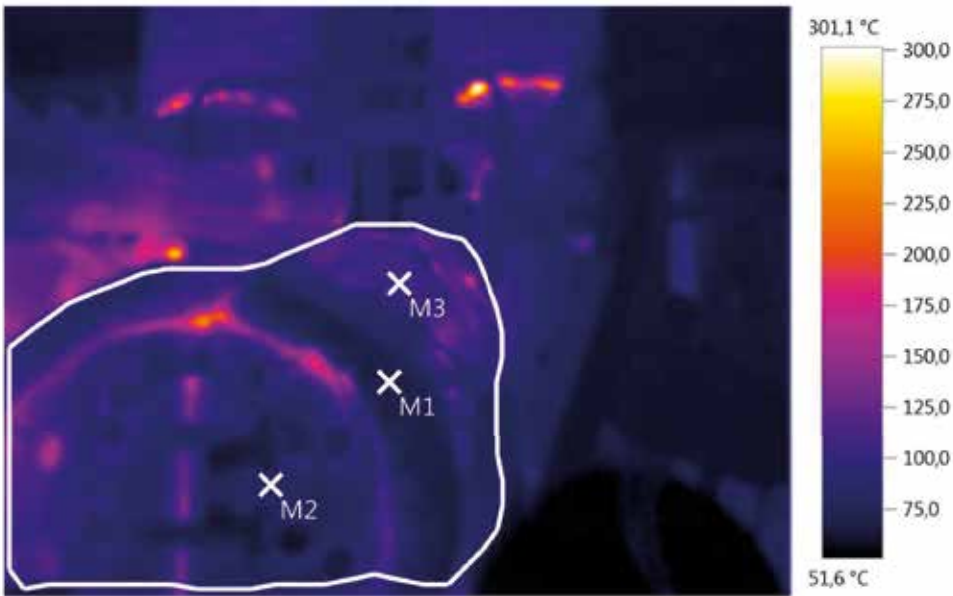

### Parameters

Emission value: 0,91

Reflection temperature (°C): 54,6



### Measuring points

Object	Temp. (°C)	Emiss.	Reflected temperature (°C)
Point 1	69,9	0,91	54,6
Point 2	80,2	0,91	54,6
Point 3	105,9	0,91	54,6

### Histogram

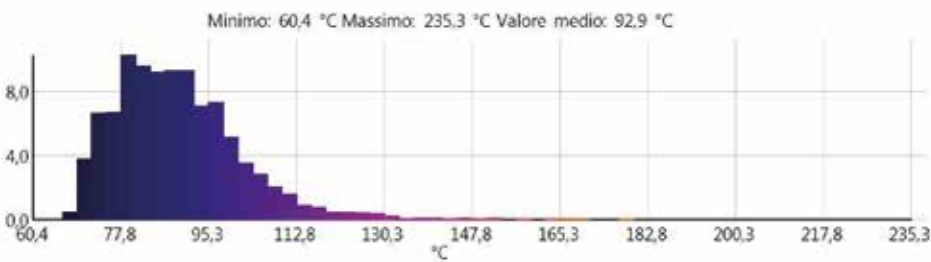

# MAINTENANCE

Insulating pillows need sometimes to be installed by highly skilled staff to guarantee their best efficiency.

New Composit has got a service team of many dedicated people ready to reach every part of the world in few time.



Cost saving and maximize energy efficiency are not so often taken into consideration in the industrial plants. Energy cost is increasing and it's expected to increase further therefore the gap between current insulation and a cost effective one is increasing as well. Additional costs for CO2 emission allowances will accelerate this trend and increase the savings potential.



Insulate bare surface at a cost effective level and replace damaged insulation requires an initial investment. One time investment grants an high potential save that with current price level is big money save every year. Investment payback time is usually less then one year.

## HOW TO ACT?

- Insulate uninsulated parts and replace damaged ones will reduce energy consumption by 3%
- Upgrade existing insulation to a more efficient one r educe current heat loss by 60%





# ENERSAVE

Optimize consumption while preserving the environment and saving money



## TECHNICAL FEATURES

- Removable
- Flexible
- Lightweight
- Customizable
- Hard-wearing
- Useful

Enersave insulation are flexible and removable pillows for valves and flanges. They are preferable to traditional insulation systems thanks to their easier handling and light-weight. Use of enersave pillows, in addition to avoid heat dispersion, helps prevent injuries which might occur due to accidental contacts with valves or flanges not insulated.

For years we have also been official members of **Eiif** (European Industrial Insulation Foundation); our accredited staff has obtained the certification to access the plant, carry out the inspections and draw up insulation studies based on energy saving.

We look for custom-made solutions by studying the specific needs of customers; we analyse the annual consumption and losses, we calculate the potential savings according to 3 factors:

- Heat loss [MWh]
- Money loss [€]
- Emissions in atmosphere [tCO<sub>2</sub>]

In the end, by means of **TIPCHECK** calculation tool (Eiif certified), we can simulate different possibilities, to find the most suitable solution, in relation to environmental and safety conditions of the plant.



## Maximum thermal protection

Flexible thermal insulation systems, easy to install and/or remove, are often required in plants where needs for frequent maintenance dictate their use. New Composit responds to this kind of requirement with a range of products, including different kind of insulation blankets, featuring high performances in terms of heat reduction, noise control, installation and removal convenience for plant maintenance. Our pillows are manufactured using high quality materials designed to grant reliable services throughout a long working life, as well are respectful both for human health and the environment.

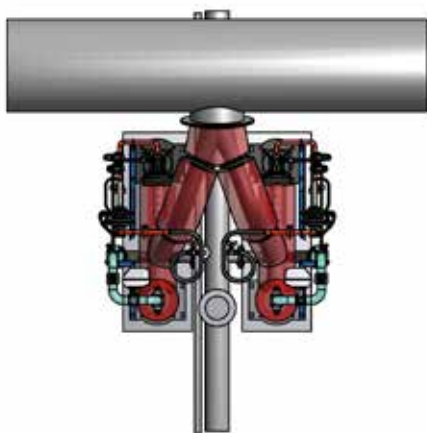

Heavy duty fan insulation



Boat boiler



Flexible jackets , specifically designed to withstand temperatures of 600°C and above, to be installed indoors or outdoors, in a neutral environment as well as in an acid one; the thermoproof type is certainly the most versatile product in our range of insulation jackets .



Insulation for SCR



Scrubber



Piping and turbine



Insulation for food plant

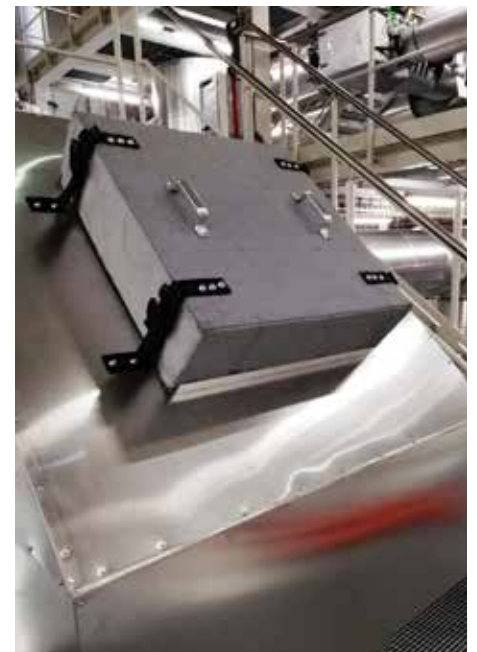

Hybrid solution



# THERMOPROOF

Maximum operational versatility

New Componit, together with its technical staff, can make on site surveys all over the world, studies according to client's drawings of the item to be insulated, draft design and final 3D drawings, interfacing advanced computerized automatic cutting systems, delivering absolute dimensional accuracy.



Gas turbines



Steam turbines



Diesel engines



Exhaust pipes



Thermal stations

Thermo/Acoustic systems



Marine silencers



Diffusers

More applications:

- Compressors
- Cogeneration plants
- Food industry
- Chemical plants
- Pharmaceutical plants



# NANOTECH

## Insulation to the nth degree

They are realized with different nanotechnology materials depending from the application. They are used in heat applications but also in cold systems and against fire. Thanks to their small thickness you can install them everywhere there's no free space... Materials are bought from the most famous supplier worldwide and quality is always on top.



## TECHNICAL FEATURES

- High tech
- Space-saving
- Efficient
- Customizable



# TERMO-JACKET

TERMO-JACKET is a textile product complete with a heating system and external control designed and proposed by NEW COMPONENT.

It is a flexible system equipped with self-regulating heating cables that keep the temperature of the insulated part up to 240°C, regardless the external temperature (down to a minimum of -50°C).



It has been optimized to work in parts of a system with particularly low temperatures, it mainly acts as an antifreeze tool. This use is strictly necessary to keep the liquids in their physical state and check their viscosity; we should also add that the flowing of thick liquids such as oils, waxes and chocolate requires their heating in order to ensure the proper conservation.

Our heating jackets are perfect when the traditional trace heating doesn't work or is difficult to install; they are safe, effective and intuitive and they offer a valid alternative to more expensive, complicated and above all not-removable systems.





## TERMO-JACKET

has been designed to fulfill the following purposes:

- Antifreezing
- Keeping the temperature
- Heating



Extremely adaptable they can be used in several industrial fields, the main are:

- pumps
- valves
- tanks and basins
- pipes
- generators

The TERMO-JACKET adapt perfectly to any shape of the components to be insulated. In case of large surfaces they can be assembled and the electrical cables are connected by means of convenient and fast connectors.



# PROSOUND-JACKET

PROSOUND-JACKET is a textile product designed with absorbent materials and special acoustic barriers, able to reduce the noise of industrial equipment. Our purpose is to reduce directly the noise at its origin, by wrapping the noise source with a flexible jacket. It is a real alternative to the classic system, which provides a metal structure placed on the floor and surrounded by insulating panels. Our Prosound-jackets are specially designed to be easily installed, removed and replaced, helping maintenance and fixing up of equipments.





## SPECIAL FEATURES

- They can be realized with any shape
- Easy to install
- Quick to uninstall and reinstall during maintenance activities
- Lasting over the time
- Weather resistant

From a technical point of view, the added value of Prosound-Jacket is that of providing a double solution in the same product: acoustic and thermal insulation at the same time, in a flexible and light jacket, that can be perfectly adaptable to any shape.

This advantage means:

- Economic savings because you don't have to buy 2 different solutions
- Further savings because you don't have to install the 2 solutions
- Smaller installation space required
- Reduced setting time

An important noise reduction of the system means:

- Improvement of general health
- More safety
- Environmental protection





The purpose of Passive Fire Protection (PFP) systems is to protect critical flow, process and safety equipments against fire damage and to allow safe controlled plant shutdown in the event of a fire. This means that critical equipment, controls and instrumentation must be able to operate throughout a specified protection period. NEW COMPONENT PFP consists in flexible jackets to be directly installed on valves or actuators and any kind of equipment that need to be protected from fire for safety reasons.



Flexible PFP on actuated valve





We know there are environments where the risk of fire is higher and impossible to be eliminated, and this is why it is necessary acting in order to prevent possible disasters.

Where:

- Petrochemical plants
- Refineries
- Platforms
- Ships





We can offer a range of different solutions according to technical specifications required by the customer and based on certifications by the most important certification bodies:

- PYROPROOF® follows UL1709 Standard up to 120 minutes, Pool Fire (Lloyd's Register Certified)
- PYROPROOF® follows ISO 22899 Standard up to 120 minutes, Jet Fire (Bureau Veritas Marine Certified)



Test - Jet Fire



Blast Test



Test - Type Approval



Test - Pool Fire



PYROPROOF® is a **FLEXIBLE**, fire protection... so it means it is a multilayer of fabrics and insulation blankets.

The product nevertheless is absolutely hard-wearing.



## SPECIAL FEATURES

The main characteristics of our system:

- May fit to any shape
- Easy to be installed (and removed if necessary)
- No need to shut-down the equipment or the line during maintenance
- Weatherproof, resistant to UV rays and salty environment
- Lighter and easier to be handled than metal PFP boxes
- It is a thermal insulation
- It is an insulation against noise too
- It can be supplied with heating system for cold environments



# R & D DEPARTMENT

We invest in research and development to guarantee the best solutions ever, today and tomorrow.

We designed and built a test bed where to test our products before delivery. In this way we are sure to achieve the best reliability and safety conditions.

We can test raw materials and final products, from fabrics to joints, from blankets to pillows. Our test bench can work at very high temperature; your products can be tested to the extreme...

We also fit out an acoustic bench test to test performances of our sonic horns.

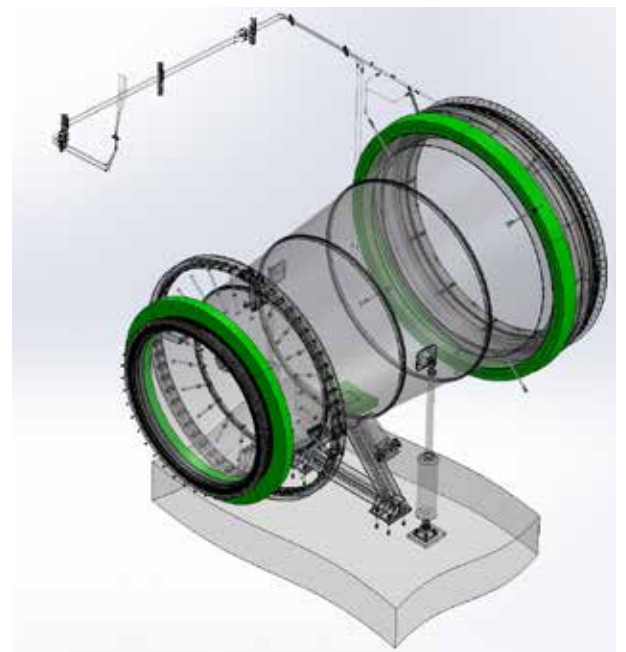



# REFERENCES

Some of our customers...

- Airlife
- Boldrocchi
- Fenice
- Franco Tosi
- Fincantieri
- GE Oil&Gas
- GE Energy
- Isab
- Isolfin
- Navigazione Laghi
- Nespresso
- Nestlè
- Servovalve
- Siemens
- Solar Turbines
- Sorgenia
- Teknowool
- Turboden
- Zambon
- Zaverò
- Wartsila



# NEW **COMPONIT**

textile solutions for heat treatment

## FLEXIBLE INSULATING SYSTEMS

**ENERSAVE** - Invest once, save every year

**THERMOPROOF** - Maximum thermal protection

**NANOTECH** - Insulation to the nth degree

**TERMO-JACKET** - **Your guarantee against the cold**

**PROSOUND-JACKET** - **Your partner against the noise**

**PYROPROOF®** - The flexible passive fireproofing protection

## CERTIFICATIONS AND PARTNERS

**Ours is a choice of safety and quality**

A further guarantee for those who work with us

- ISO9001:2015  
Quality System
- ISO14001:2015  
Environmental Management System
- ISO45001:2018  
Systems for Health and Safety  
Management of Workers
- ISO9712:2012  
Themographic Analysis
- UL1709  
Pool Fire: Fire resistance test
- ISO22899  
Jet Fire: Fire resistance test
- TBI/TIPCHECK  
EiiF accreditation for  
Certified Energy Saving Analysis



**NEW COMPONIT Srl**

Via delle Rimembranze 5, 22070 Cirimido (CO) - Italy

Tel. +39 031.89.55.80 - Fax +39 031. 35.20.787

info@newcomponit.com - [www.newcomponit.com](http://www.newcomponit.com)